

SolidDrive SD1

SD1, SD1g, SD1sm, SD1 Desktop

Sound Transducer

Technical Information for System Engineers



SOUNDTUBE
ENTERTAINMENT

SD1, SD1sm



SD1g, SD1 Desktop



SPECIFICATIONS: SD1, SD1g, SD1sm, SD1 Desktop

Mounting hardware included

System Type	Direct drive, on-surface, or in-wall
Impedance (nominal) ¹	8 ohm
Sensitivity dB @ 2.83V/1M	70 - 75 dB ¹⁰
Sensitivity dB @ 1W/1M ²	73.5 dB ¹⁰
Frequency Response (-3 dB) ³	80 Hz - 10 kHz
Frequency Response (-10 dB) ³	60 Hz - 15 kHz
Max. Program Power ⁴	50 w
Max. Continuous Power RMS ⁵	30 w
Max. Power SPL @ 1 M ⁶	88.5 dB
Coverage Angle (-6 dB @ 2 kHz)	120°
Coverage Angle (-6 dB @ 10 kHz)	120°
Transducer	SolidDrive SD1
Enclosure Material	Chrome plated aluminum
Grille	N/A
Inputs	Wire lead with screw connector block
Colors	SD1- Chrome, Titanium SD1g- Chrome, Black, Titanium SD1sm- Chrome, Black, Titanium
Height	51.3 mm (2.02 in)
Diameter	58.4 mm (2.30 in)
Weight	0.5 kg (1.2 lb)
Shipping Weight	0.9 kg (2.0 lb)
Accessories	
Optional	Wood EQ, Drywall EQ, Glass EQ, Pre-Construction Bracket, SD1 Wall Bracket, 20 Watt Transformer, Heat Sink Fins
Packaging	1 per box
Regulatory - CE	Approved
Regulatory - UL	Approved UL 1480 & 2043 (Except SD1-Desktop)
RoHS	Approved

Notes:

- 1 Impedance listed per IEC 60268-5
- 2 1w1m sensitivity determined using nominal impedance
- 3 Frequency response measured in half or full space as dictated by speaker mounting configuration
- 4 Max program power is 3 dB above max continuous power
- 5 Continuous power rating EIA-426-B test
- 6 Max output based on max continuous power
- 7 Max useable SPL based on testing by NWA Labs
- 10 Equivalent to conventional in-wall @ 4m
- 11 With 100 Hz 12 dB / oct high pass filter
- 12 Since radiation is from a large surface, the decrease in SPL with distance is significantly less than conventional in-wall speaker (-6 dB/doubling), thus causing an apparently higher sensitivity at listening distances.

Key Features

- Proprietary dual-voice coil technology in a durable, aluminum enclosure delivering high power handling and sensitivity across multiple substrates.
- Symmetrically opposed neodymium magnets convert audio signals into acoustical energy for any rigid surface including glass, drywall, ceramic and wood.
- Hidden planar-source audio technology evenly distributes acoustic energy throughout the listening space.
- Proprietary behind-surface mounting technologies ensure maximum visual appeal.
- 88.5 Max SPL (drywall) and 120° dispersion pattern across the upper registers of the frequency spectrum.
- Drywall (SD1) optional accessories: self-leveling, constant tension pre-construction bracket to ensure proper alignment & wall contact.
- Glass (SD1g) included accessories: high-bond, double-sided VBH adhesive disk.
- Wood, laminate & composite (SD1sm) included accessories: direct-screw aluminum mounting base.
- Desktop included accessories: mini amplifier, 15 Volt power supply, passive EQ module, 4 international power outlet adaptors, connector cables and a durable carrying case.
- Optional accessories include passive EQ modules for drywall, glass or wood; 20 Watt metal junction box for 25, 70.7 & 100 Volt applications (AC-JB20-XFMR) and Heat Sink Fins
- For extended frequency response, couple SolidDrives with SW7 or SW8 subwoofers.
- SolidDrives operate in a virtually friction-free environment and are engineered for infinite life. SolidDrives come with an industry-leading 7-year warranty.
- UL approved 1480 and 2043 (except SD1-desktop).

Description

The SolidDrive utilizes patent-pending dual-voice coil technology in an aluminum enclosure to transfer acoustic energy to any substrate. Symmetrically opposed neodymium magnets and specifically engineered mounting hardware results in hidden planar-source acoustics. The result is acoustical uniformity throughout the listening space.



Commercial Applications

SolidDrive technology and patented mounting mechanisms allow for high quality sound through rigid substrates including drywall, glass, wood, laminate & ceramic. Applications include retail, restaurant, boardroom, tradeshow, presentations and more. With planar-source technology, the location of the SolidDrive on the surface has no impact on the quality or uniformity of the delivered sound field. For bass response down to 40 Hz, SolidDrive SW7 (7 inch) or SW8 (8 inch) subwoofers can be included. An optional 20 Watt transformer is supplied in a junction box and is available for 25, 70.7 or 100 Volt applications.

SolidDrive EQ Modules

The surface material plays a key role in the system's sound performance. To ensure an optimal listening experience, the SolidDrive SD1 system can be equalized with the optional SolidDrive Passive Equalization Module (Not UL approved). Each PEM increases the system's sound performance with a passive equalizer network specifically engineered for the particular substrate it is intended for. One module is used with each SolidDrive and are available for drywall, wood, and glass. The SD1 Desktop model ships with the PEM for wood included.

Patented Technologies

SoundTube Entertainment and the MSE Audio Group constantly develop new technologies which enhance audio product performance. SoundTube Entertainment innovations are protected by multiple U.S. and international patents, which explicitly cover SoundTube dome, enclosure and dispersion technologies. The MSE Audio Group actively defends its patents in order to protect SoundTube resellers and end-users.

Technical Data and Specification Tools

Technical Data

SoundTube Entertainment strives to provide complete and effective technical information and data to dealers, engineers and designers. All data are available from SoundTube Entertainment or at www.soundtube.com.

Technical data and downloads include:

EASE™ data – 3-D polar plots.

EASE™ Address – 2-D modeling for distributed systems

Autodesk® Revit® software

Tech Sheets – Technical information and architectural specs for system engineers

SoundTubeSPEC™ – Proprietary speaker placement software

Independent Data Acquisition and Verification

All data for SoundTube speakers are independently collected and verified by NWA Labs (www.nwaalabs.com) using their proprietary MACH testing system. All data are collected and analyzed according to ASTM, ISO and AES standards using EASERA, TEF and MLSSA. Full balloon data including both phase and magnitude are compiled into a variety of formats including EASE 4.x, GLL and CLF.

Architectural Specifications

The loudspeaker shall consist of a full-range transducer constructed with neodymium magnets in a chrome-plated aluminum enclosure.

Performance specifications are dependent upon substrate type and size. Typical production unit specifications are as follows: Useable frequency response shall extend from 60 Hz – 15 kHz (-10 dB, ½ space, no external equalization). Measured sensitivity (2.83 Volt input, 1 meter) shall be at least 70.0 dB (drywall tested). The speaker shall have a nominal impedance of 8 Ohms and rated power capacity shall be at least 30 Watts RMS. The max. SPL shall be 88.5 dB (drywall tested).

Installation for the SolidDrive shall include galvanized steel pre-construction bracket for drywall, high-bond, double-sided VBH adhesive for glass or direct-screw mounting plates for surface-mount applications including wood. The desktop mounting kit includes mini amplifier, 15 Volt power supply, passive EQ module, 4 international power outlet adaptors, connector cables and a durable carrying case.

Overall cabinet dimensions for the SD1 and SD1sm shall be no more than 52.8mm (2.08 in) in height by 88.9 mm (3.50 in) in diameter. The SD1 shall weigh no more than 0.50 kg or 1.2 Lbs.

Overall cabinet dimensions for the SD1 Desktop and SD1g shall be no more than 52.8 mm (2.08 in) in height by 57.9 mm (2.28 in) in diameter. The SD1 shall weigh no more than 0.50 kg or 1.1 Lbs.

SolidDrive models shall come with the following leads:

SD1 – 559 mm (22 in.) plenum rated speaker wire with screw connector block.

SD1g – 1829mm (72 in) clear speaker wire with screw connector block.

SD1sm – 1829mm (72 in) clear speaker wire with screw connector block.

SD1 desktop – 1829mm (72 in) black speaker wire with gold RCA plug.

SoundTube Entertainment

6430 North Business Park Loop
Park City, Utah 84098
Phone 435.647.9555
Fax 435.647.9666
Toll Free 800.647.TUBE
www.soundtube.com

All SoundTube products come with a 5-year limited warranty.



Frequency Response – Typical Dry-wall SolidDrive Response

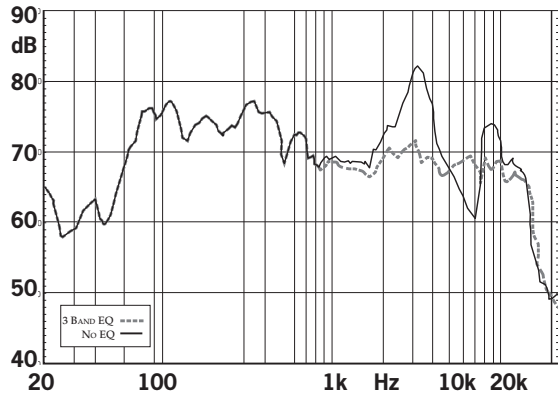

Frequency Response – Typical Wood Table-Top SolidDrive Response

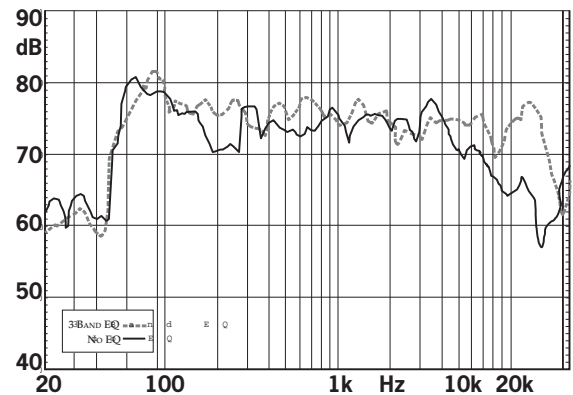

Frequency Response – Typical Glass SolidDrive Response

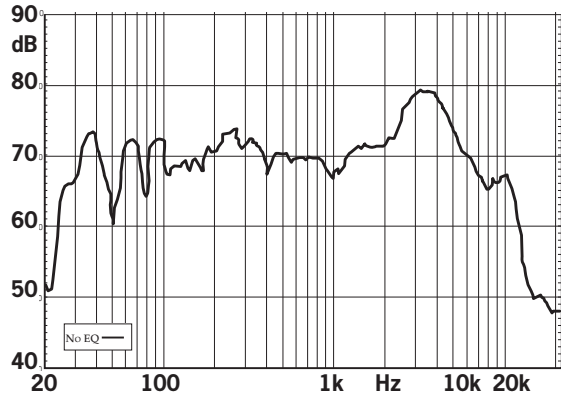

Directivity Index (DI) - Off Axis Response On 4x8' Drywall Panel Outdoors in 4' Direction Referenced to 0deg @2m

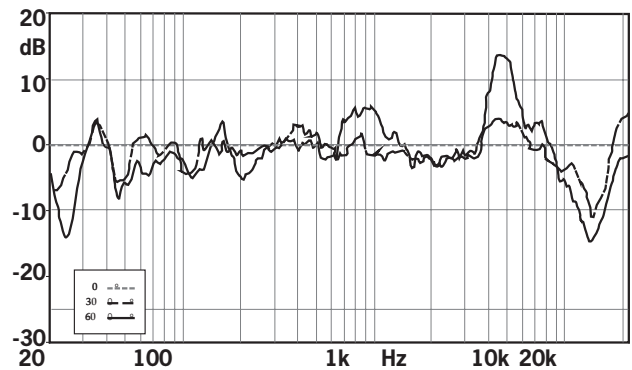

Dry-Wall Passive EQ

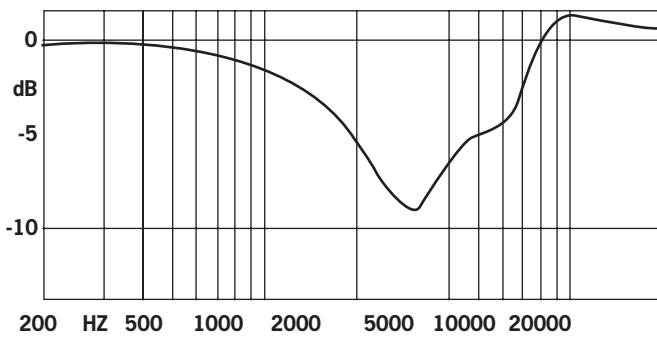

Glass Passive EQ

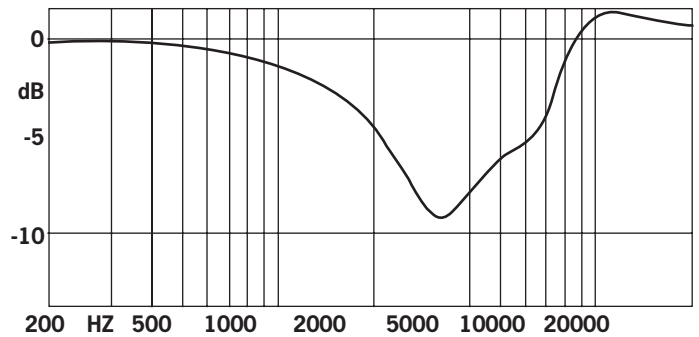

Wood/Desktop Passive EQ

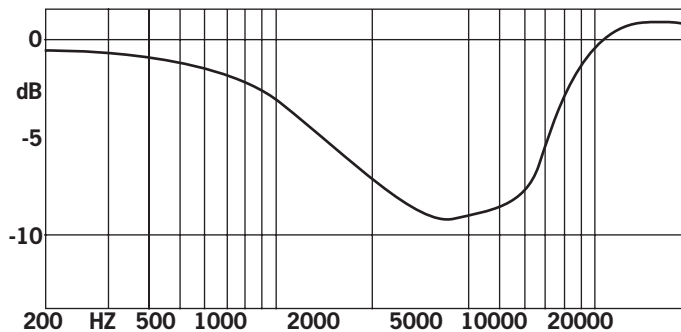

SolidDrive SD1

SD1, SD1g, SD1sm, SD1 Desktop

Sound Transducer

Technical Information for System Engineers



SOUNDTUBE

ENTERTAINMENT

Mechanical Drawings

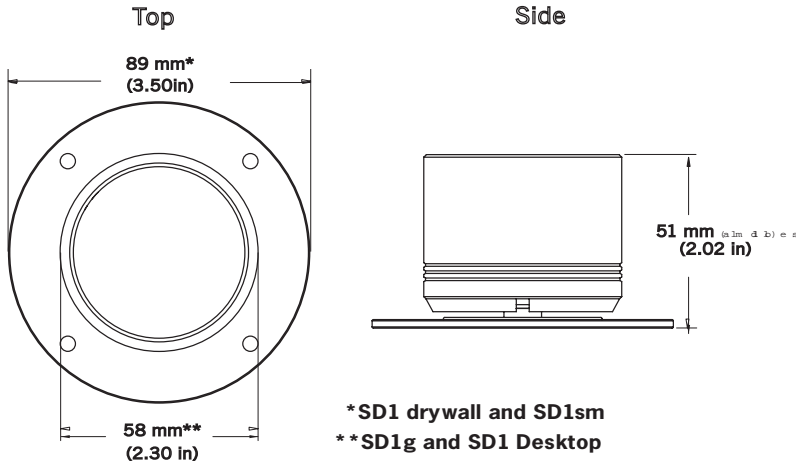

Optional Accessories

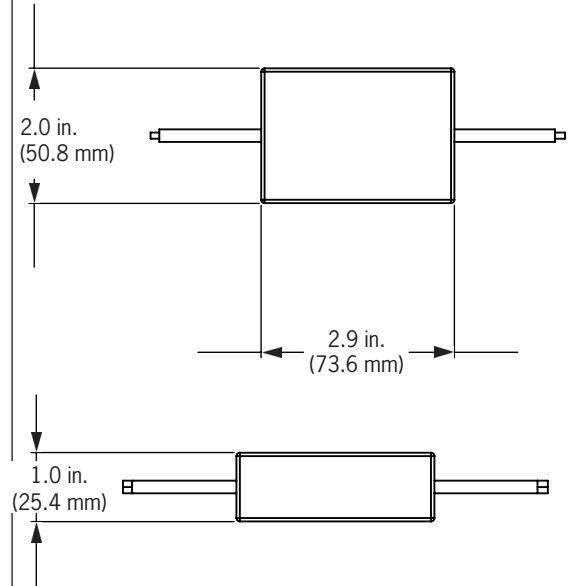

Passive Equalization Modules

- PEM-D Drywall EQ for SD1
- PEM-W Wood EQ for SD1sm on wood
- PEM-G Glass EQ for SD1g

Passive EQ Module Included with SD1 Desktop Kit

Mounting Options

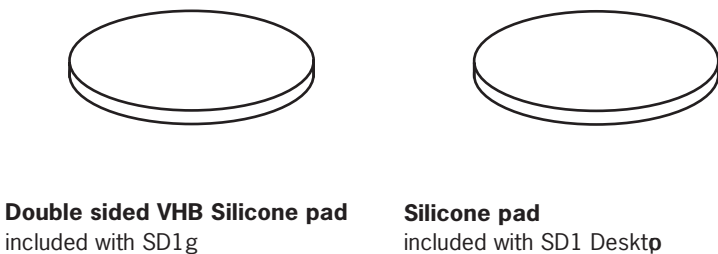
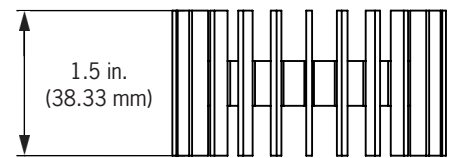
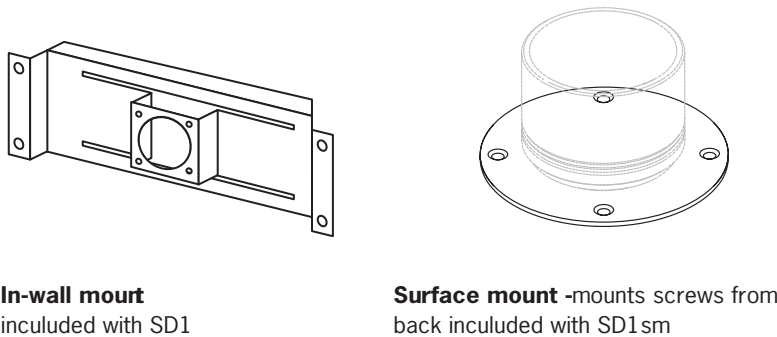

Heat Sink Fins

Slide on around drive to disperse heat

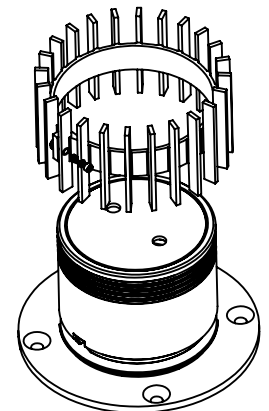

SoundTube Entertainment manufactures a complete line of speakers for:
Open-Ceiling • In-Ceiling • Surface-Mount • Outdoor • Sound-Focusing

All SoundTube products are designed and engineered in the USA.